

JAVA

Instrucciones de montaje

Assembly instructions

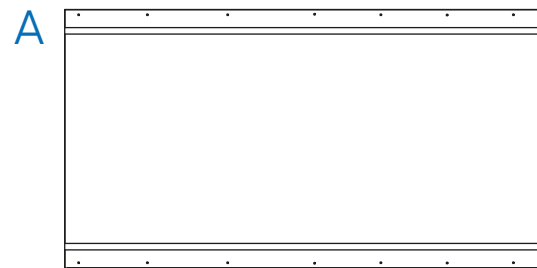
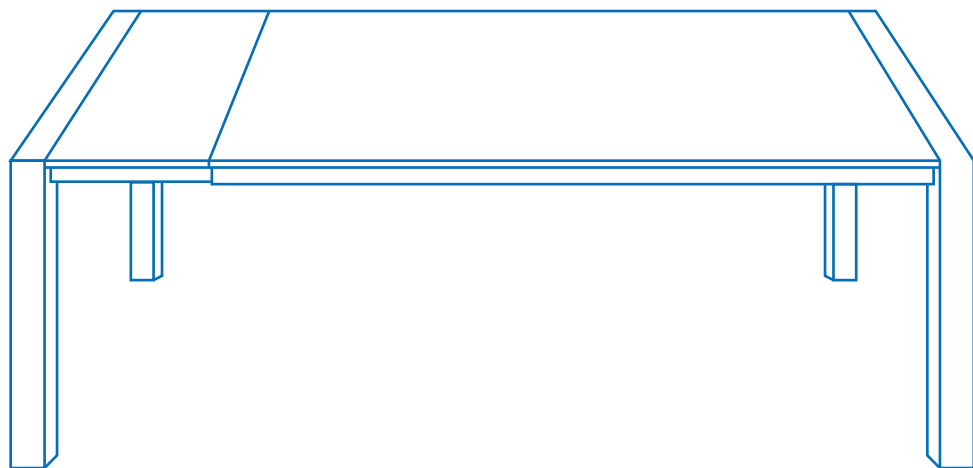

1PC

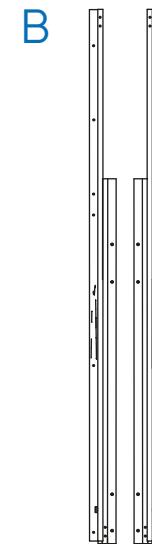

2PC

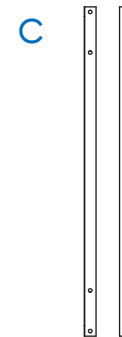

2PC



8PC



12PC



4PC



4PC



4PC



16PC



12PC



8PC



4PC



12PC

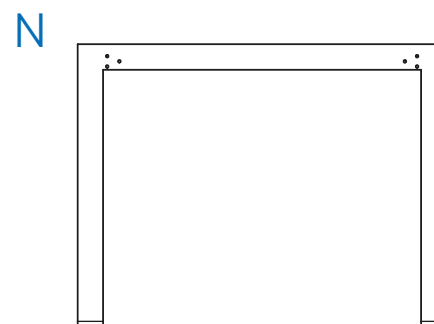

N

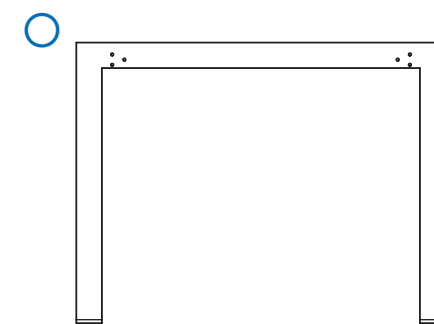

O

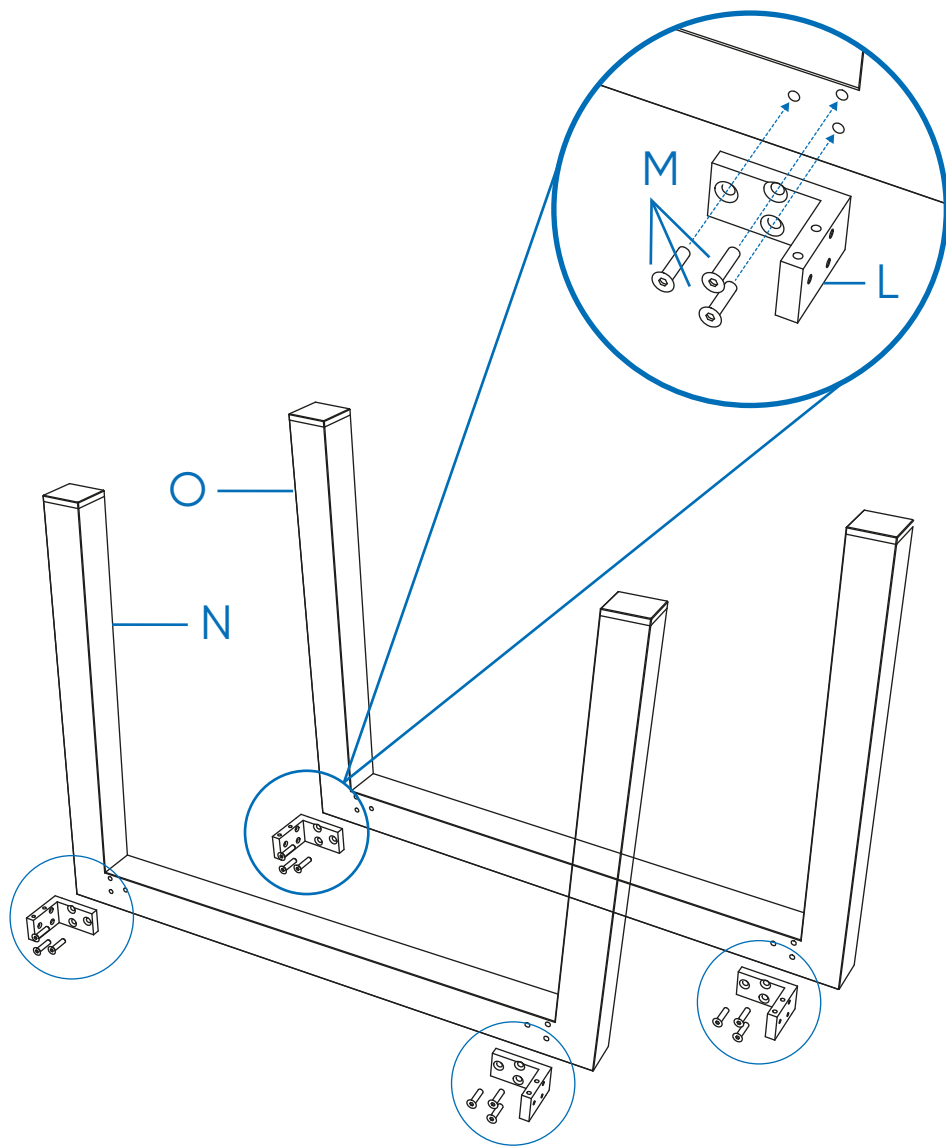

Paso/Step #1

Fije las escuadras L a cada uno de los extremos de las patas N y O, orientándolas hacia el exterior, mediante los tornillos M (x3).

Attach brackets L to each end of legs N and O, facing outward, using screws M (x3).

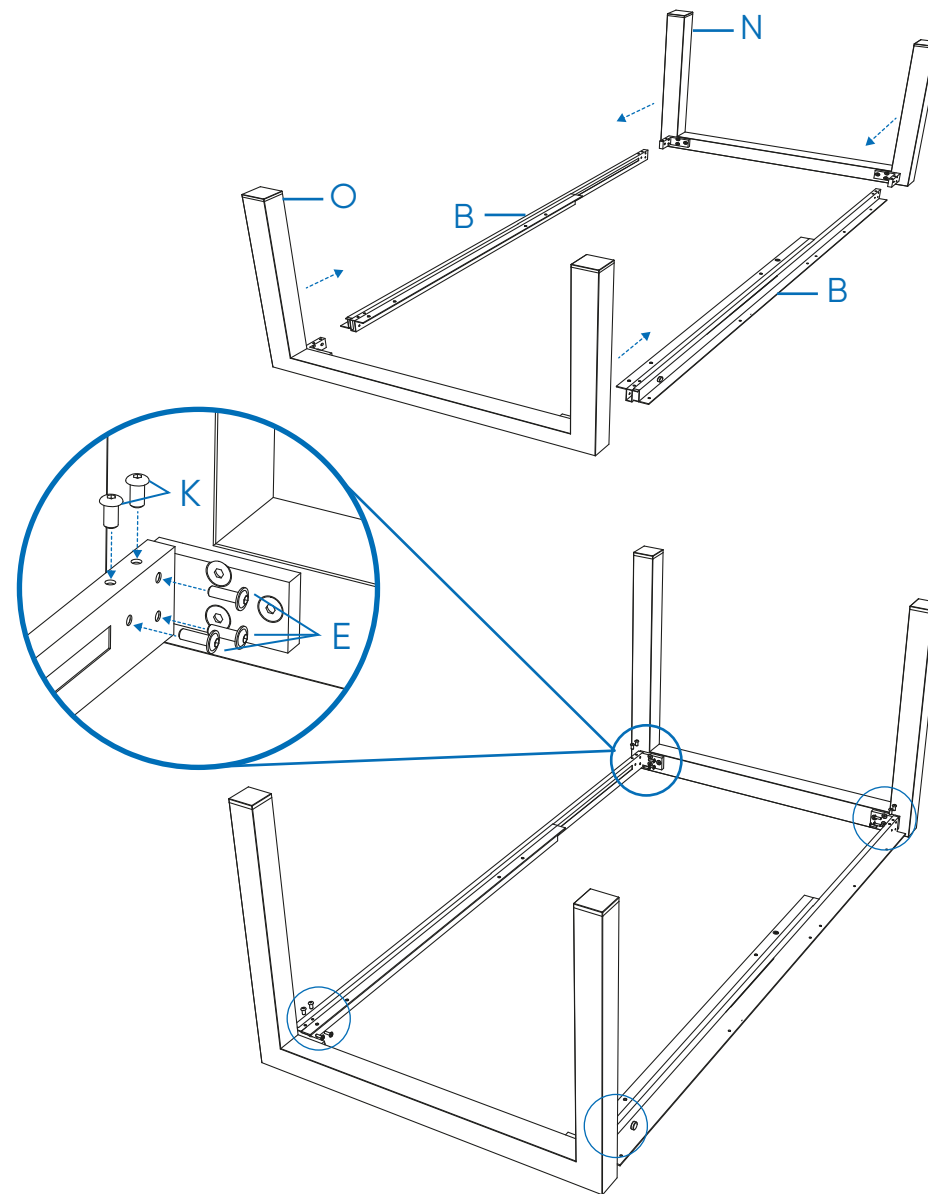

Paso/Step #2

En el otro extremo de la escuadra, una los laterales B y fijelos mediante los tornillos E (x3) en la parte interior y los tornillos K (x2) en la parte exterior.

At the other end of the bracket, join side panels B and secure them using screws E (x3) on the inner side and screws K (x2) on the outer side.

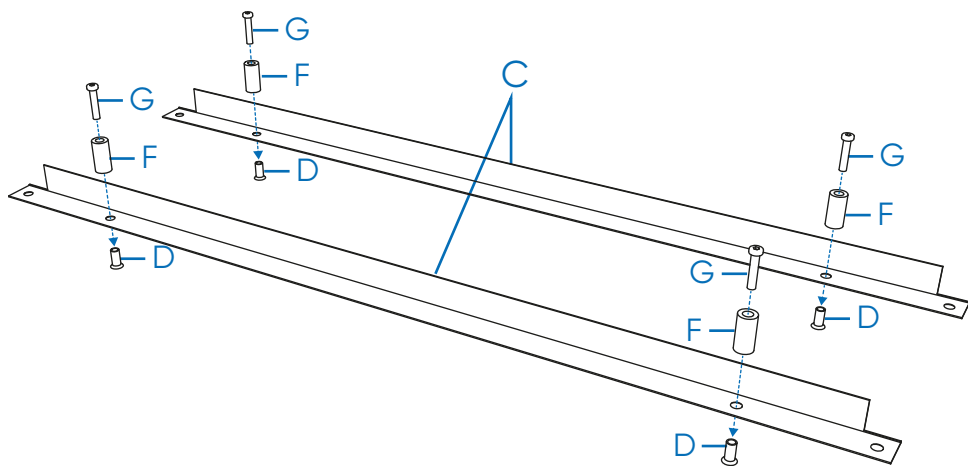

Paso/Step #3

En las barras C, coloque en los dos orificios interiores el separador F, introduciendo el tornillo G en un extremo y el tornillo D en el otro

On bars C, place spacer F into the two inner holes, inserting screw G at one end and screw D at the other.

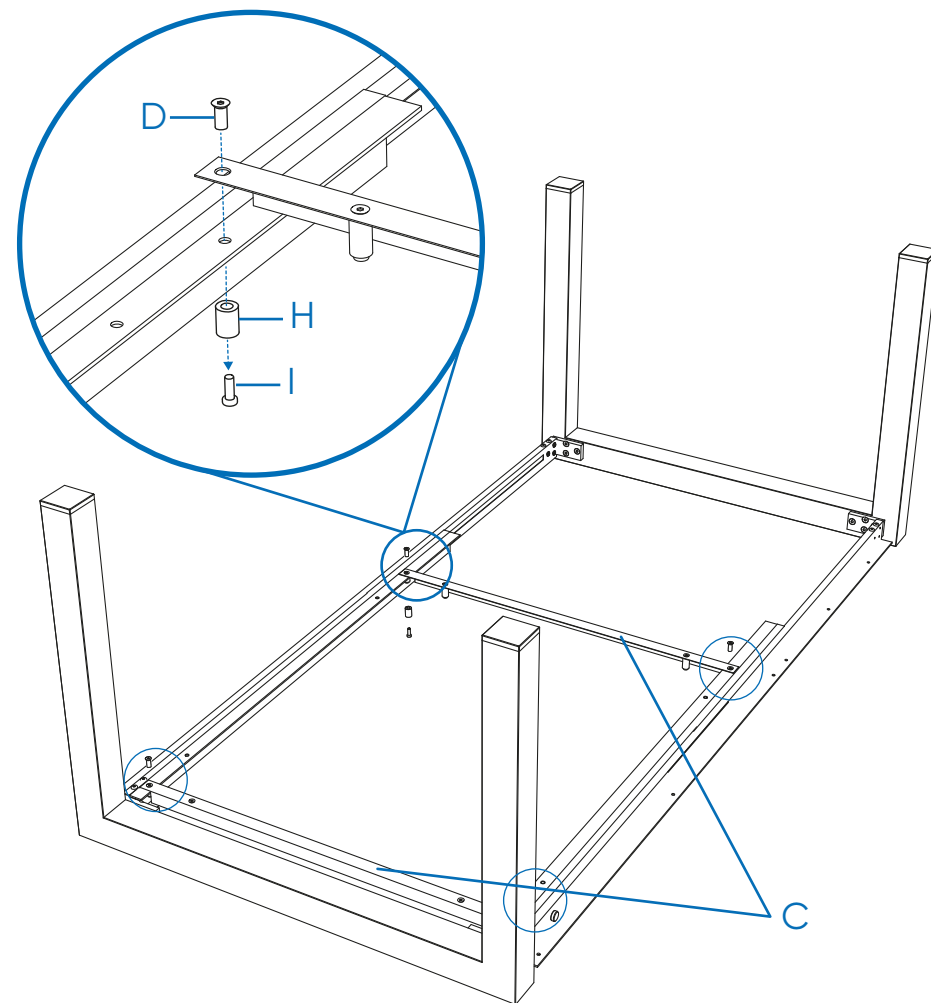

Paso/Step #4

Una las barras C a la estructura montada utilizando los orificios exteriores de las barras. Coloca el separador H y el tornillo I en un extremo y el tornillo D en el otro.

Join bars C to the assembled table frame using the outer holes of the bars, fitting spacer H and screw I at one end and screw D at the other.

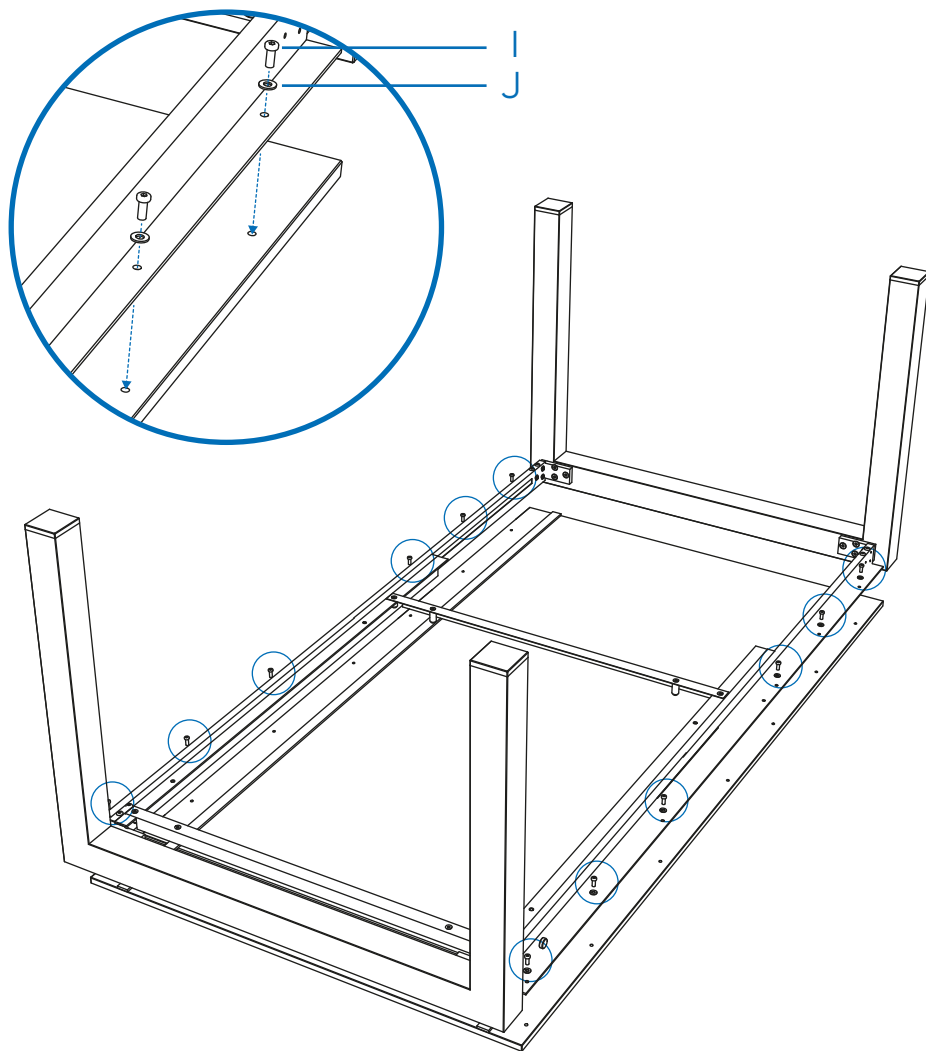

Paso/Step #5

Monte el tablero A a la estructura de la mesa utilizando los tornillos I y las arandelas J

Mount tabletop A onto the table frame using screws I and washers J.

Balliu Export S.A.

Ctra. C-35, Km 93,5
17455 - Caldes de Malavella
Girona (Spain)
Tel. +34 972 397 100
info@balliuxport.com

www.balliuxport.com



Always sunny